



215 SERIES

MODELS

215ADC38/12

215ADC38/24



FEATURES

- Oil-less, non-lube piston and cylinder
- Stainless steel valves
- Lightweight, die-cast aluminum components
- Built-in check valve
- Hard-coated aluminum cylinder for maximum piston wear life
- Balanced for smooth, low vibration operation
- Long-life, high performance PTFE compound piston ring
- Inlet unloader or pressure restart
- Built-in inlet filter
- Field service capability
- Dust and moisture resistant
- Permanently lubricated motor shaft and connecting rod bearings

Consult factory for custom applications

Thomas Division is an ISO 9001 registered company

THOMAS
A Gardner Denver Product

215 Series Performance Data

MODEL NUMBER		215ADC38/12		215ADC38/24	
HEAD CONFIGURATION		Pressure Only		Pressure Only	
STROKE		.380 inches		.380 inches	
PRESSURE		Flow @ 12v		Flow @ 24v	
CFM @ PSI	LPM @ bar				
PSI	bar	CFM	LPM	CFM	LPM
0	0	.97	27.5	.92	26.1
10	.5	.87	25.4	.82	24.0
20	1.0	.76	23.2	.72	22.0
30	1.5	.66	21.1	.62	19.9
40	2.0	.61	19.6	.57	17.8
50	3.0	.53	16.5	.50	15.4
60	5.0	.46	11.6	.43	10.8
70	7.0	.42	8.3	.39	7.2
80		.38		.35	
90		.34		.30	
100		.30		.26	
110		.25		.22	
120		.22		.19	
MAX. CONTINUOUS PRESSURE					
MAX. INTERMITTENT PRESSURE		120 PSI	8.3 bar	120 PSI	8.3 bar
MAX. DUTY CYCLE (MINUTES ON/OFF AT 23°C)		10% (3 on / 30 off)		10% (3 on / 30 off)	
MAX. AMBIENT AIR TEMP.		158° F	70°C	158° F	70°C
MIN. AMBIENT START TEMP.		-40° F	-40°C	-40° F	-40°C
MAX. RESTART PRESSURE					
MOTOR VOLTAGE/FREQUENCY		12v DC		24v DC	
MOTOR TYPE		Permanent Magnet		Permanent Magnet	
CURRENT AT RATED LOAD (AMPS)		16.0		7.5	
POWER AT RATED LOAD (WATTS)					
STARTING CURRENT (LOCKED ROTOR, AMPS)		50.0		26.0	
CAPACITOR VALUE					
MIN. FULL LOAD SPEED (RPM)		3650		3400	
THERMAL PROTECTOR					
NET WEIGHT		3 lbs.	1.4 Kg	3 lbs.	1.4 Kg

The information presented in this material is based on technical data and test results of nominal units. It is believed to be accurate and reliable and is offered as an aid to help in the selection of Thomas products. It is the responsibility of the user to determine the suitability of the product for his intended use and the user assumes all risk and liability whatsoever in connection therewith. Thomas Industries does not warrant, guarantee or assume any obligation or liability in connection with this information.

NOTE: Models pictured are representative of the series and do not represent a specific model number. Consult factory for detailed physical description.

215ADC

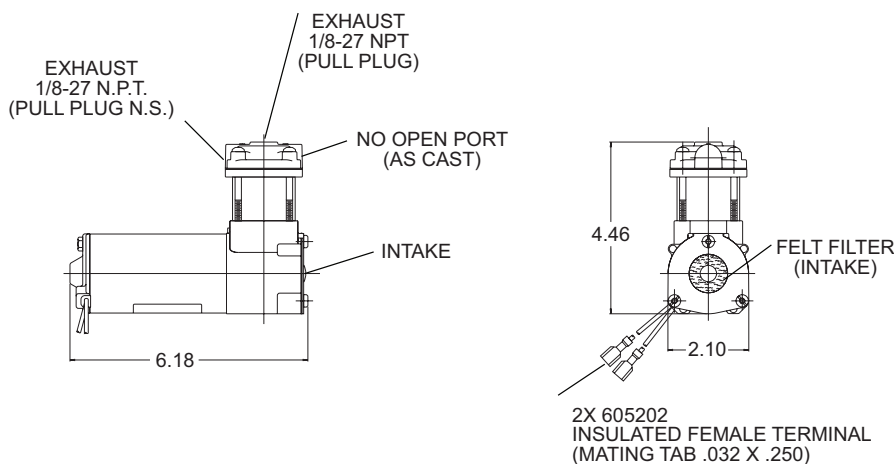

THOMAS
A Gardner Denver Product

Thomas Division
1419 Illinois Ave
Sheboygan, WI 53081 USA
Phone: (920) 457-4891
Fax: (920) 451-4276
www.gd-thomas.com

Printed in U.S.A. Form No. 850-3289 11/11
©2007 Gardner Denver Thomas, Inc. All rights reserved.